

DEVELOPMENT AND TESTING OF THE ARMOR PLATE PIPELINE REPAIR SYSTEM

Christopher R. Alexander
Stress Engineering Services, Inc.
Houston, Texas

Fred D. Wilson
Armor Plate, Inc.
Pasadena, Texas

ABSTRACT

The introduction of composite pipeline repair methods has been a source of great interest over the past several years. The primary aim of these repair methods is to reinforce the damage done to pipelines by both corrosion and mechanical damage (such as dents and gouges), while alleviating the need for welding and in some cases repairing pipelines. Typically, these repair processes involve issues such as strength restoration, reducing strain in the damaged area, and sealing the damaged area of the pipe from further development of corrosion.

The Armor Plate pipeline repair system was developed to address these issues utilizing a comprehensive experimental test program. Testing focused on the specific aspects of the adhesive/composite system in addition to application of the wrap repair on corroded and mechanically-damaged pipe. Strain gage testing quantified the restraint provided to a corroded pipe by the composite material. Also addressed were the effects of cyclic pressure service on degradation of the repair material. This paper is designed to provide the reader with an understanding of the critical issues associated with the development of a composite pipeline repair system and the methods Armor Plate, Inc. employed to address them.

BACKGROUND

There are numerous possibilities available for experimentally validating a composite pipeline repair wrap. To date, the most comprehensive research program has been funded by the Gas Research Institute in evaluating the Clock Spring repair system (Kuhlman, 1995 and Stephens, 1998). Numerous insights have been gained regarding composite pipeline repairs as a result of this research.

Testing the Armor Plate Pipe Wrap 360 system (APPW 360) initiated in November 1997. Since that time numerous tests have been conducted to assess the performance of the wrap in repairing corroded and mechanically-damaged pipe. Efforts have also been undertaken to gain a greater understanding of the wrap's mechanical behavior and the transfer of load that occurs from the pipe to the composite wrap material.

While having established a foundation for evaluating the APPW 360 system, certain aspects of the design require continued investigations. The main area of interest is additional testing to address the long-term performance of the repair. Although it has been proven that the wrap performs well in terms of hydrostatic capacity and limited cyclic pressure service, the long-term aspects of the design remain untested.

INTRODUCTION

This section of the paper provides the reader with an understanding of the critical issues associated with the development of a composite pipeline repair system. While not exhaustive, this discussion focuses on how a composite repair wrap can restore burst strength and reduce strain in the damaged area of the pipe.

The burst pressure of a pipe is directly related to the ultimate strength of the pipe material for a material possessing an adequate level of ductility. While yielding of the material is certainly important, it is not directly involved in the calculation of burst strength. The hoop stress in thin-walled pipe (*thin-walled* considered for pipes where the ratio of pipe radius to wall thickness is greater than 10) is determined using Barlow's equation (derived using classical mechanics),

$$\sigma_{hoop} = \frac{P \cdot r}{t}$$

where:

σ_{hoop}	Hoop stress (psi)
P	Internal pressure (psi)
r	Average radius (inches)
t	Wall thickness (inches).

The *average radius* is computed taking the average of the inside and outside radii of the pipe. The previous equation can be rearranged to determine the burst pressure of a pipe assuming a specific ultimate strength.

For example, the burst pressure for a 16-in x 0.375-in pipe with an ultimate strength of 75,000 psi is computed as follows,

$$P_{burst} = \frac{\sigma_{ult} \cdot t}{r} = \frac{75,000 \text{ psi} \cdot 0.375 \text{ inches}}{7.8125 \text{ inches}} = 3,600 \text{ psi}$$

It is apparent from the previous equation that if the ultimate strength of the pipe is increased, the burst pressure of the pipe will also increase (assuming that the piping material possesses an adequate level of ductility). This observation leads to the relationship that is established when a composite sleeve is placed over a region of the pipe. Two objectives are accomplished in installing a composite sleeve. First, the thickness of the cross-sectional area resisting the internal pressure force is increased. Secondly, another material with different yield and ultimate strengths and elastic moduli (in most circumstances) than the pipe is introduced. The thickness of the composite material in conjunction with its ultimate strength determine the level of reinforcement provided when a repaired section is taken to burst-level pressures.

Figure 1 shows a cross-sectional view of a pipe and a composite wrap installed on the outside of the pipe. This schematic illustrates how the pipe and wrap mechanically resist the force created by the internal pressure.

The mechanical resistance provided by the pipe and wrap are governed by the equal and opposite relation shown in the following equation,

$$F_{pressure} = F_{pipe} + F_{wrap}$$

If these terms are expanded to represent stresses and cross-sectional areas (per unit length), a new equation is derived,

$$P \cdot r = \sigma_{pipe} \cdot t_{pipe} + \sigma_{wrap} \cdot t_{wrap}$$

which can be rearranged to calculate the burst pressure for a given pipe/wrap combination,

$$P_{burst} = \frac{\sigma_{ult_{pipe}} \cdot t_{pipe} + \sigma_{ult_{wrap}} \cdot t_{wrap}}{r}$$

For purposes of experimentally validating the previous equation, consider the results from a previous test. Consider the data for test sample *Pipe #2*,

Pipe size: 6.625-in x 0.280-in pipe, 47.5 ksi yield strength and 70.6 ksi ultimate strength
 Wrap: 4 wraps - 0.25 inches total thickness, tensile strength of 26.4 ksi (based on tensile testing)

The test sample had a 4-in x 4-in corroded region that was 50 percent of the wall; however, because of local reinforcement from the adjacent pipe material the thickness used in the burst equation is 60.8 percent (0.170 inches) of the actual pipe wall (Kiefner, 1990). The average wall

thickness in the corroded region of the pipe is 3.1025 inches. Therefore, the computed burst pressure for both the pipe and wrap is,

$$P_{burst} = \frac{(70,600 \text{ psi} \cdot 0.170 \text{ inches}) + (26,400 \text{ psi} \cdot 0.25 \text{ inches})}{3.1025 \text{ inches}} = 5,995 \text{ psi}$$

This calculated value corresponds well to the experimental burst pressure of 6,170 psi for sample *Pipe #2*. This pressure is also close to the calculated burst pressure for the same pipe geometry with no corrosion (6,231 psi).

The other issue to be addressed in assessing the performance of a pipeline repair system is the level of restraint provided to decrease strain in the reinforced pipe section. Calculations associated with this topic are more complicated than those already presented because of the issues related to plasticity of the pipe material. From a loading standpoint, the following sequence of events occurs when a repaired corroded region is pressurized so that plastic flow is induced in the material,

1. The pipe and composite are both stressed as the internal pressure is increased. The stiffer of the two will be stressed to a higher level (with composite repairs this is typically the pipe material). Stiffness for the piping configuration at hand is computed using the following equation,

$$k = E \cdot t$$

where: E Modulus of elasticity of material (psi)
 t Thickness of material (inches)

2. Once the corroded section of the pipe begins to yield, its relative stiffness is reduced. At this point the wrap begins to be the critical source of strength for the assembly. Basically this phase of loading can be modeled assuming that the pipe material has a modified (reduced) modulus related to the slope of the yield to ultimate strengths.
3. The final burst pressure is governed by the ultimate capacities of the pipe and wrap material.

In addressing the performance of a corrosion pipeline repair, there are several fundamental questions,

- How much pressure can be applied to the repaired section before it will either leak or rupture (as a minimum this pressure should induce a stress equal to 100 percent of the minimum specified yield strength)?
- How does the repair perform when addressing environmental issues such as cyclic pressure, soil conditions, and temperature variations?

The former question and cyclic pressure portion of the latter question have been addressed specifically with past testing of Armor Plate Pipe Wrap (Alexander et al., 1998b and 1998c). Issues such as long-term exposure to the environment require a testing program with a length of several years. It is the intent of Armor Plate, Inc. to address these issues over the next several years by implementation of a long-term testing program.

EXPERIMENTAL TEST PROGRAM

To validate APPW 360 as a viable pipeline repair method, an initial testing program has been developed. The major components of the current test program are,

- Repair of corrosion
- Cyclic pressure effects on burst pressure of a repaired corrosion sample
- Repair of mechanical defects
- Load transfer from pipe to wrap using strain gages
- Tensile testing of the APPW 360 composite material
- Lap shear testing to address the interface between the composite and steel.

Presented in this section of the paper are the test methods and results associated with the investigation of these experimental variables.

Repair of Corrosion

Several samples were fabricated to address the reinforcement of corrosion using APPW 360. Corrosion defects were machined in 6 inch and 12 inch nominal diameter pipes. The axial corrosion lengths were selected so that without repair the corrosion would have failed at a pressure less than the *safe maximum pressure* per ASME B31G. These corroded sections of pipe, assuming they were present on an actual pipeline, would need to be removed, repaired, or have the operating pressures reduced.

Listed in **Table 1** are the sample descriptions and test results for the corrosion test samples. The minimum pressure that any repair should achieve is the 100 percent Specified Minimum Yield Strength (SMYS) pressure; however, the APPW 360 system is designed to provide reinforcement up to two times the B31.4 *maximum operating pressure* or B31.8 *maximum allowable operating pressure* (144 percent SMYS) assuming that the appropriate number of wraps is applied.

As noted in all three tests, the burst pressure for the repaired samples exceeded not only the 100 percent SMYS pressure, but were also greater than the predicted failure pressures for the base pipe material assuming no defects were present. None of the repaired samples failed at pressures less than the expected burst pressure for pipe without corrosion or defects.

Cyclic Pressure Effects on Burst Pressure

In an effort to address the effects of cyclic pressure on the strength of APPW 360, a test sample was cycled 3,290 times prior to conducting a burst test. Data is provided in **Table 1** relating to this particular test, Sample *WC-4F*. As shown, the burst failure pressure for this sample is equal (within 24 psi) to the burst pressure for the non-cycled test, Sample *WC-3B*. Based upon an industry survey relating to typical operating pressure fluctuations for liquid pipelines (Fowler et al., 1994), pressure fluctuations of this order (1,100 psi) would occur less than 500 times per year. This being the case, the 3,290 cycles for Sample *WC-4F* correspond to approximately six years of service in a liquid pipeline. In contrast with liquid service, cyclic pressure is typically not an operating issue for gas pipelines (pressure fluctuations of 200 psi every five months, Fowler et al., 1994)

Repair of Mechanical Damage

Mechanical damage was installed in two pipe samples by creating a 15 percent dent (15 percent of the pipe's outer diameter) and a 10 percent gouge (gouge depth percentage of pipe wall thickness). Although there is no closed-form solution readily available to predict the burst pressure for this defect, previous research indicates that a defect of this order is sufficient to reduce the burst stress below 100 percent of the specified minimum yield strength of the pipe (Alexander et al., 1997a). The two samples were fabricated from 6.625-in x 0.280-in pipe and were 5 feet in length. The pipe material used in this test had a yield strength of 47,500 psi and an ultimate tensile strength of 70,600 psi. Using Barlow's equation with the given pipe geometry and ultimate tensile strength, the expected burst pressure for this pipe is 5,967 psi.

Figure 2 is a photograph of the load frame used to install the dents. Prior to installation of the dents in Samples #3 and #4, one gouge having a depth of 0.028 inches (10 percent of wall thickness) and a length of 10 inches was installed in each pipe. These gouges were oriented longitudinally. The base of the gouges resembled a Charpy V-notch in that a 0.002 inch radius tip was machined with a bevel angle of 60 degrees.

Once the gouges were installed, the pipes were placed in the *Dent Installation Rig* shown in **Figure 2**. This set-up was used to impress the indenter (in this case a 4-inch nominal heavy-wall end cap) using a hydraulic ram. Once each dent was installed, the indenter was removed and the pipe was permitted to reround elastically. The initial indentation of 1.0 inches did not rebound significantly as indicated by the remaining depths (0.781 inches for Pipe #3 and 0.836 inches for Pipe #4). The final dent depths before conducting the burst tests were 12.6 percent and 11.8 percent for Pipes #3 and #4, respectively. Indentation loads of 33,061 lbs. and 32,531 lbs. were required to create the dents in Samples #3 and #4, respectively.

After the dents were installed, the pipes were ready for testing, or in the case of Pipe #4, the APPW 360 repair wrap was installed prior to conducting the burst test. **Table 2** provides a listing of the test samples selected for this phase of the program. Sample #3 was an unrepaired defect (experimental control case), while Sample #4 had a similar defect, but was repaired with APPW 360. Also, provided in this table are the test results.

In comparing the results for these two samples, it is shown that the repair increased the burst pressure of the dented and gouged section from 3,750 psi to 5,820 psi, or by 55 percent. While a closed-form solution for predicting burst pressure for mechanical damage is not available, the experimental results are still significant. From a repair method standpoint, the results indicate that the burst pressure for the given sample was restored to the approximate burst pressure for an undamaged section of pipe. As with the corrosion testing, one of the primary objectives in repairing any defect is the ability of the wrap to increase the burst strength of a damaged section to the same level as expected for an undamaged pipe.

Strain Gage Testing

Strain gages were installed on one section of a 16-in x 0.375-in, grade X52 pipe to determine the level of restraint provided by the APPW 360 repair system. In addition to the gages installed under each of wrap, three exterior gages were installed on the pipe away from the wraps. These locations served to indicate the level of nominal strain in the pipe due to internal pressure.

An 8-in x 8-in corrosion area having a depth of 50 percent was machined into the 0.375 inch wall. This thickness was verified to be 0.188 inches using a hand-held ultrasonic meter. Two biaxial strain gage rosettes were installed in this region. One was placed in the center of the corrosion, while the other was offset 2 inches along the axis of the pipe.

Prior to installing the wrap, the pipe was sandblasted to a near-white metal finish with a 2.5 to 3-mil anchor pattern. End caps were then attached to the pipe by welding. The wrap was installed with no internal pressure in the pipe. The remaining steps in terms of installing the wraps were conducted by Armor Plate, Inc. personnel and are as follows,

- Primed surfaces where the wrap was to be installed with Armor Plate 360 A&B
- Filled in the corrosion region of the sample using AP360 epoxy putty
- Installed wraps having 8 layers over the corroded region
- The edges of the wrap were puttied with Armor Plate Pipe Wrap 990 A&B epoxy putty
- The wrap was cured under a tent arrangement for 7 hours using kerosene heaters (estimated wrap/pipe temperature of 100 °F).

After the wrap was permitted to cure, the strain gages and associated cables were connected to a data acquisition system. This equipment was necessary for monitoring the strain gages during the pressurization process. This step was the last procedure conducted before testing the wraps.

The level of internal pressure was related to the minimum specified yield strength for the pipe. The X52 grade pipe has a SMYS of 52,000 psi which corresponds to a pressure of 2,438 psi. According to ASME Codes for liquid and gas piping, the allowable stress is limited to 72 percent of SMYS (for B31.4 all cases and for B31.8, Division 1, Class 2 - *pipelines, mains, and service lines*), which for the given pipe corresponds to an internal pressure of 1,755 psi. Using these two pressure values (1,755 and 2,438 psi), a pressure sequence was developed for testing the pipe sample. **Figure 3** shows the pressure-time map used in loading the sample. The three pressure cycles shown were applied three different times, being designated as *Run #1* and *Run #2*, and *Run #3*. The purpose in repeating the pressure cycles was to provide information relating to the hysteresis of the system.

The properties for the 16-inch pipe according to the Mill Test Report were,

- Yield strength of 68,900 psi (API Spec 5L minimum yield strength of 52,000 psi)
- Tensile strength of 88,500 psi (API Spec 5L minimum tensile strength of 66,000 psi)
- Elongation of 35.0% (API Spec 5L minimum of 23.5%).

As can be seen from these values, the tested pipe far exceeds the minimum values for the X52 grade piping material as specified by the American Petroleum Institute's (API) Specification 5L.

While strain gages were installed in the corroded region of the 16-inch pipe beneath the wrap, no measurements were taken in this region without reinforcement. For this reason a finite element analysis (FEA) model was constructed to determine the strains in an unrepaired corroded region.

Figure 4 provides the analytical results with the experimental values for the strain gages located in the corroded region beneath the APPW 360 wrap. In the finite element model, strains were extracted from the same location as the strain gages placed on the 16-inch pipe test sample.

In studying the information in **Figure 4**, there are several noteworthy observations,

1. In the initial pressurization, the wrap does not provide significant reinforcement to the corroded region of the pipe. This is validated in observing that the sub-wrap strain values differ little from the nominal pipe strain readings.
2. During the later stages of the pressurization (after approximately 2,000 psi internal pressure), the strain in the pipe increases significantly. It is at this point that the wrap begins to take on the load required to provide restraint to the pipe. At the maximum pressure of 2,438 psi, it is apparent that the wrap is providing reinforcement to the corroded region. Using the previous equations and the ultimate strength of the pipe, the calculated burst pressure for the corroded region without reinforcement is 2,476 psi.
3. Using the hand calculations and FEA results, it is apparent that the pipe repair is providing reinforcement once the corroded region exhibits yielding. If the APPW 360 repair was not installed, the two sets of plotted curves would be more closely related.

While strain gages were not installed in a corroded region that was not repaired, the finite element analysis provides useful information relating to the expected stress/strain levels. This comparison of results provides insights as to the mechanical behavior of the wrap and at what pressure the transformation of the load from the pipe to the wrap occurs.

Composite Tensile Testing

Armor Plate, Inc. fabricated several flat panels of the APPW 360 composite material. The approximate dimensions for each of the panels were 6 inches wide by 12 inches long, with thickness being dependent upon the number of layers. Testing was conducted on two and four-layer samples. Identical 1-in wide x 8-1/2-in long samples were prepared from each of the panels. The fibers of the composite were oriented with the long direction of the samples. Prior to testing, the widths and thicknesses of the samples were measured as listed in **Table 3**.

Tensile testing was conducted using a constant cross-head speed of 0.05 inches/minute in a laboratory temperature of 70°F. The output for the testing procedure was load and deflection; however, using the cross-sectional area of the samples and gage length, stress and strain were computed, respectively. Also obtained as a result of the testing was the modulus of elasticity. The modulus of elasticity, E, is calculated by

dividing change in stress by change in strain for the linear portion of the load-deflection curve. During the testing, deflection was only monitored to approximately 75 percent of failure due to the potential for damaging the deflection-measuring extensometer at the point of rupture. Results are presented in **Table 3** including failure strain, failure stress, and modulus of elasticity.

All failures occurred in the vicinity of the grips and not within the gage length (middle section) of the samples. For this reason, the stress at which failure occurred cannot be labeled as ultimate, but represents a lower bound failure strength. The average lower bound failure stresses for the AP 360 formulation, AP 360 long pot life formulation and the 350°F cured material are 26,442 psi, 27,564 psi and 27,266 psi, respectively.

Lap Shear Testing

While testing has been reported herein relating to the performance of the pipeline wrap in reinforcing pipe defects as well as determining the composite tensile strength, information has not been presented relating to the adhesive bond between the pipe and composite. The most effective method for evaluating this interface is by using lap shear samples. In this application, the lap shear testing method uses either steel or composite adherends to test the adhesive bond. As shown in **Figure 5**, the adherends are assembled to create a tensile coupon with a test zone having an area of one square inch. The sample is loaded to the point where failure occurs. This failure shear stress is known as the lap shear rupture strength. In addition to the rupture method of loading, the lap shear samples can be used to determine creep in the adhesive bond considering a specified load, temperature and time period.

Armor Plate, Inc. fabricated two panels involving a steel-on-steel assembly and a composite-on-steel assembly. The approximate dimensions for each of the assembled panels were 7 inches wide by 9 inches long. The nominal adhesive thickness for the samples was 0.010 inches. From these panels, 1-inch wide samples were cut. Prior to testing, the widths and thicknesses of the samples were measured and are listed in **Table 4**.

Of the two lap shear adherend combinations, the composite-on-steel lap shear sample is more representative of the actual application. In addition to the general strength of the composite material, the bond between the pipe and steel pipe (adhesive interface) determines the structural integrity of the repair method.

The lap shear testing was conducted using a constant cross-head speed of 0.05 inches/minute in a laboratory temperature of 70°F. The output for the testing procedure was load and deflection; however, using the cross-sectional area of the adhesive, the failed shear stress was computed. Results are presented in **Table 4** including elongation at failure and failure stress.

The steel-on-composite failures all resulted in fiber pull out from the composite. The average failure shear stress for the steel-on-steel and steel-on-composite samples were 1,504 psi and 1,495 psi, respectively. Had fiber pull-out not occurred with the composite material, the disbonding of the steel-on-composite samples would have occurred at higher shear stresses.

PROPOSED LONG-TERM TEST PROGRAM

The initial test program evaluated the pipeline repair system addressed issues relating to the pressure-capacity restoration of damaged pipes. Results for this test program are provided herein. While favorable hydrostatic burst and short-term cyclic have been obtained using a limited number of samples, it is recognized that long-term issues such as creep and environmental effects have not been addressed thoroughly. This section of the paper provides information regarding the long-term test program. This list below provides an outline of the testing needed to address performance of the adhesive and composite system for long-term service.

- Effects of installation pressure on performance of wrap
- Strength rupture and creep testing on the composite material (including elevated temperature testing)
- Strength rupture and creep testing on lap shear samples addressing bond strength between pipe and wrap (including elevated temperature testing)
- Cathodic disbondment and water penetrations testing (per ASTM G8 and G9 test procedures)
- Long-term composite and lap shear testing (dead weight loading in saturated environment)
- Field validation program involving installation of wraps on pipelines that will be monitored over several years. A standard method for installation and inspection should be employed for all wraps installed.

APPLICATION OF THE PIPELINE REPAIR SYSTEM

Recognizing the needs that pipeline companies have in repairing corrosion and implementation of the APPW 360 pipeline repair system, Armor Plate, Inc. developed a handbook to assist in installation of the wrap. While the handbook provides information relating to the installation of APPW 360, its primary intent was to designate the number of wraps required to repair a corroded section considering the pipe and corrosion geometries in the form of tables. The handbook provides a theoretical discussion on the methodology used to determine the required number of wraps.

The tabulated values provide a minimum reinforcement level to increase the burst pressure for a corroded section of pipe to twice the allowable operating pressure as discussed previously. This is conservative when compared to the B31G criterion, which requires that corroded regions withstand a pressure capacity equal to 100 percent SMYS.

An example problem is provided. Refer to the tabulated data provided in **Figure 6** (located in **Appendix B** of the *Handbook for Armor Plate Pipe Wrap*). Assuming the following conditions, how many wraps are required to repair this defect?

Pipe diameter:	6.625 inches
Pipe wall thickness:	0.219 inches
Pipe grade:	X42
Corrosion properties:	6 inches long and 0.110 inches deep

Referring to **Table AP-1A** (in **Figure 6**), go down the first column to find the corrosion depth (if depth is between two values, choose the larger). Once the depth is selected, go across to the right and find the appropriate length. Because 6 inches falls between 3.313 and 6.625

inches, select the longer of the two. Based upon this corrosion geometry, **5 wraps** are required to adequately repair this defect.

CONCLUDING REMARKS

Based upon results of the test program, APPW 360 has proven to be an effective method for repairing corroded and mechanically-damaged pipe by increasing hydrostatic burst capacity. In addition to the pipe testing, investigations have been conducted relating to the adhesive and composite system. These tests have also proved that the proposed repair system possesses adequate strength characteristics.

To address longevity of the repair method, the long-term test program is designed to deal with concerns relating to environmental issues and performance of the composite/adhesive system over an extended period of time under load. This document has attempted to present information relating to the current test program as well as the proposed long-term research efforts. The objective of the overall test program is to fit within a standardized method that will be required for establishing the fitness for service of composite repair methods.

REFERENCES

- Alexander, C. R., *Handbook for Armor Plate Pipe Wrap*, prepared by Stress Engineering Services, Inc. for Armor Plate, Inc., Houston, Texas, April 1998.
- Alexander, C. R., Ross, G. R. and Fowler, J. R., *Testing of Armor Plate Pipe Wrap using Tensile Coupons and Strain Gage Measurements Taken from 16" Pipe Assembly*, prepared by Stress Engineering Services, Inc. for Armor Plate, Inc., Houston, Texas, February 1998.
- Alexander, C. R. and Biel, R. C., *Experimental Testing of Armor Plate Pipe Wrap (APPW 360) - Report #2*, prepared by Stress Engineering Services, Inc. for Armor Plate, Inc., Houston, Texas, February 1998.
- Alexander, C. R. and Kiefner, J. F., *Effects of Smooth and Rock Dents on Liquid Petroleum Pipelines*, API Publication 1156 (First Edition), American Petroleum Institute, Washington, D.C., November 1997.
- Alexander, C. R., Kiefner, J. F., and Fowler, J. R., *Repair of Dents Combined with Gouges Considering Cyclic Pressure Loading*, 8th Annual International Energy Week Conference and Exhibition, Houston, Texas, January 1997.
- American Society of Mechanical Engineers, *Manual for Determining the Remaining Strength of Corroded Pipelines*, ASME B31G-1991, New York, New York, 1991 edition.
- American Society of Mechanical Engineers, *Liquid Transportation System for Hydrocarbons, Liquid Petroleum Gas, Anhydrous Ammonia and Alcohols*, ASME B31.4, New York, New York, 1992 edition.
- American Society of Mechanical Engineers, *Gas Transmission and Distribution Piping Systems*, ASME B31.8, New York, New York, 1995 edition.
- American Society of Testing and Materials, *Paint - Products and Applications: Protective Coatings; Piping Coatings*, Volume 6.02, West Conshohocken, Pennsylvania, 1998 edition.
- Fowler, J. R. Alexander, C. R., Kovach, P. J., and Connelly, L. M., *Fatigue Life of Pipelines with Dents and Gouges Subjected to Cyclic Internal Pressure*, Energy-Sources Technology Conference and Exhibition, Houston, Texas, February 1995.
- Kiefner, J. F., and Vieth, P. V., *New method corrects criterion for evaluating corroded pipe*, Oil and Gas Journal, August 9, 1990, pages 56-59.
- Kuhlman, C. J., Lindholm, U. S., Stephens, D. R., and Kilinski, T. J., *Long-Term Reliability of Gas Pipeline Repairs by Reinforced Composites*, Final Report to the Gas Research Institute, Chicago, Illinois, GRI-95/0071, December 1995.
- Stephens, D. R. and Kilinski, T. J., *Field Validation of Composite Repair of Gas Transmission Pipelines*, Final Report to the Gas Research Institute, Chicago, Illinois, GRI-98/0032, April 1998.

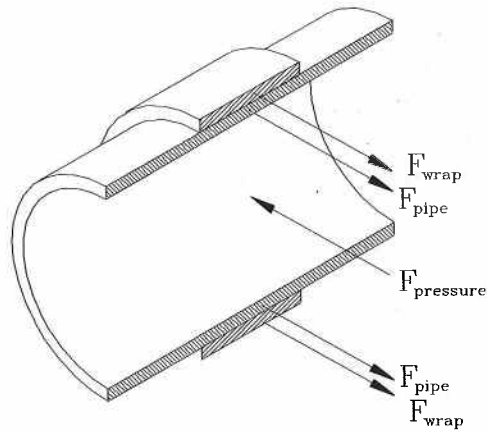

Figure 1 Cross-sectional view of pipeline repair

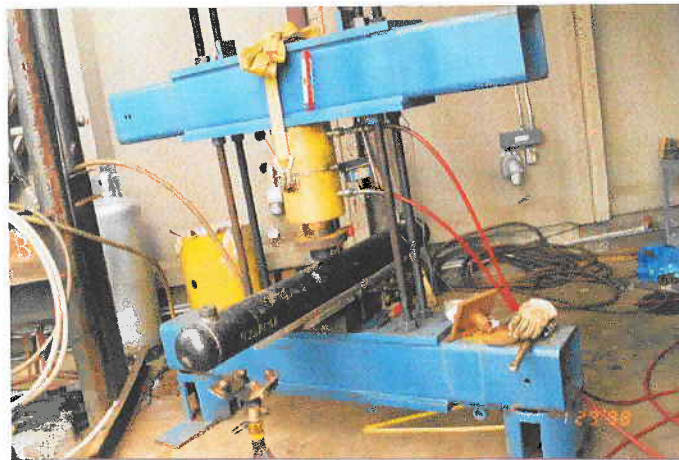

Figure 2 Photograph of dent installation rig

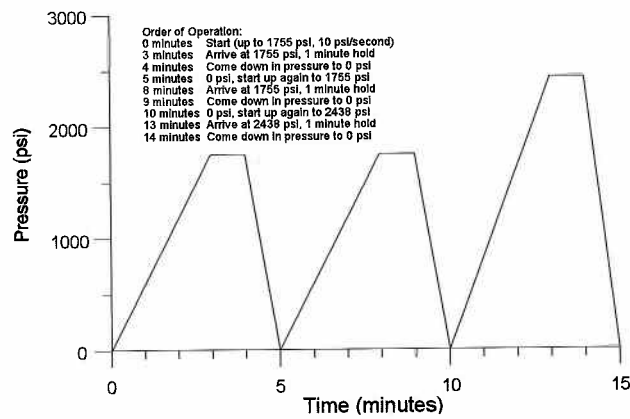

Figure 3 Experimental Pressure-time map

HOOP STRAIN AS A FUNCTION OF PRESSURE IN CORRODED REGION OF PIPE CONSIDERING EXPERIMENTAL AND FINITE ELEMENT VALUES

Calculated FEA and experimental results assume a 16" X 0.375" pipe with a 8" X 8" corrosion patch, 50% of the wall (X52 grade pipe). Experimental corroded region wrapped with 8 layers of APPW 360. Testing and analysis conducted by Stress Engineering Services, Inc.

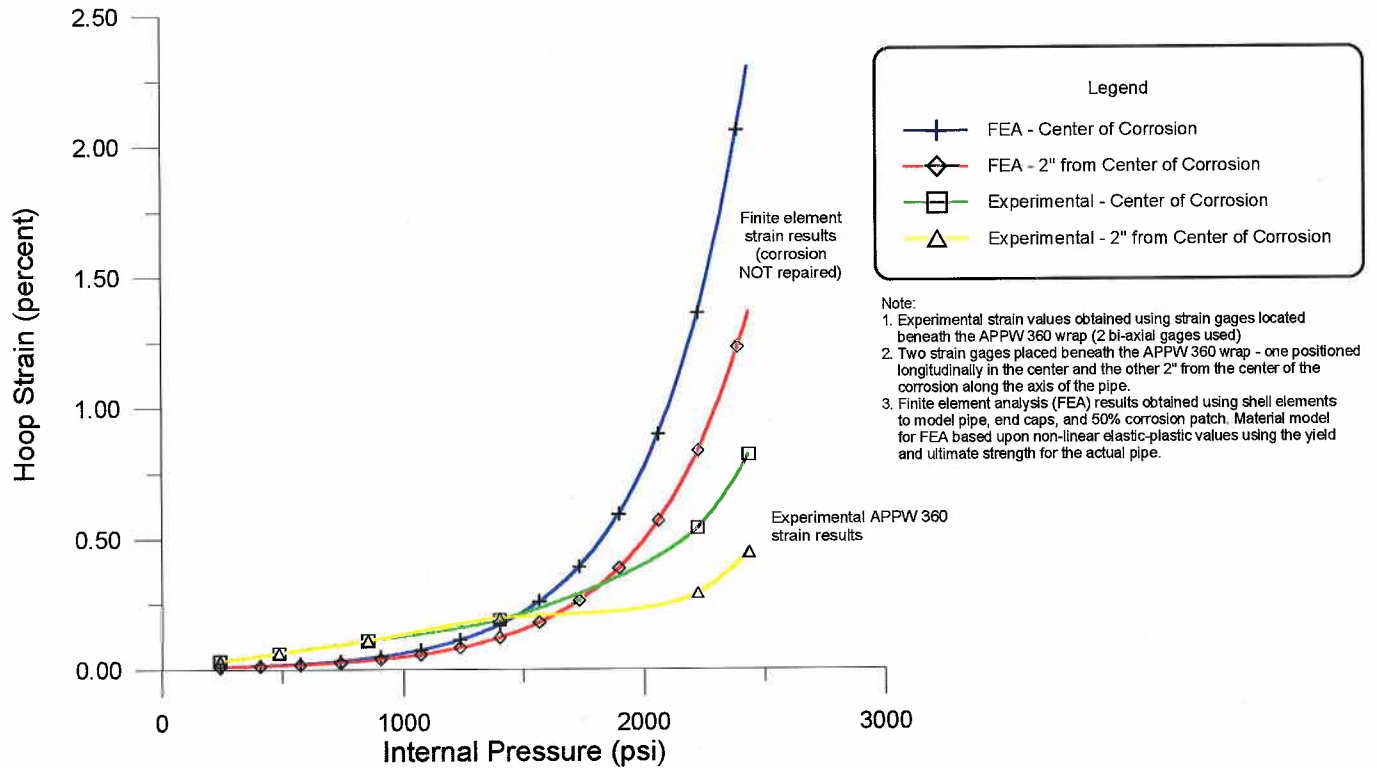

Figure 4 Hoop strain as a function of pressure for experimental and analytical work

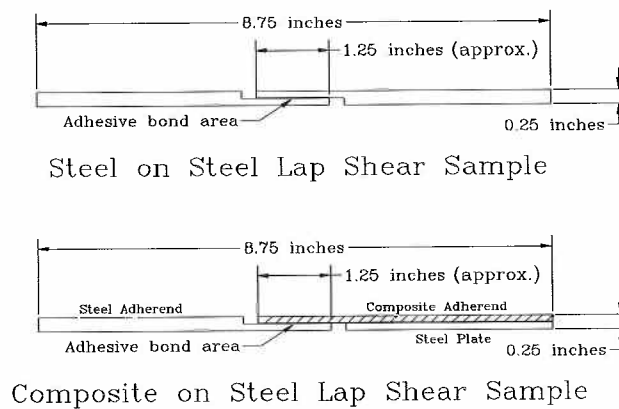

Figure 5 Configuration of lap shear test samples used in testing

Pipe Diameter (in)	6.625	Notes: 1. Repair is not required if corrosion length in table is less than the calculated limiting corrosion length, L, per B31G (see last column in table). 2. If operating pressure is greater than the calculated MAOP, then a specific calculation for the given pipe, grade and operating pressure is required. 3. If the pipe grade (e.g. X52) has a yield strength that is greater than X42 material, then a specific calculation for the given pipe, grade and operating pressure is required if a greater level of reinforcement is desired from the wrap (if wrap thickness value from table are used, result is conservative if operating pressure less than calculated MAOP at left) 4. NR in cell means that repair is not necessary per B31G for this particular corrosion length.
Pipe wall thickness (in)	0.219	
Pipe Grade (Spec API 5L)	X42	
SMYS (psi)	42000	
UTS (psi)	60000	
Wrap UTS (psi)	30000	
MAOP (psi)	1999	
Maximum permitted corrosion depth (inches)	0.175	

Required Number of Wraps									
Corrosion Depth (inches)	Corrosion Length (percentage of pipe diameter and length in inches)								L per B31G inches
	5% D	10% D	25% D	50% D	100% D	150% D	200% D	Infinite	
	0.331	0.663	1.656	3.313	6.625	9.938	13.250	10000	
0.022	NR	NR	NR	NR	1	1	1	1	5.396
0.033	NR	NR	NR	NR	2	2	2	2	5.396
0.044	NR	NR	NR	NR	2	2	2	2	3.611
0.055	NR	NR	NR	2	2	3	3	3	2.337
0.066	NR	NR	NR	2	3	3	3	3	1.799
0.077	NR	NR	2	3	3	3	3	4	1.489
0.088	NR	NR	2	3	4	4	4	4	1.282
0.099	NR	NR	3	4	4	4	4	5	1.130
0.110	NR	NR	3	4	5	5	5	5	1.012
0.120	NR	NR	3	4	5	5	5	6	0.916
0.131	NR	NR	4	5	6	6	6	6	0.836
0.142	NR	NR	4	5	6	6	6	7	0.767
0.153	NR	NR	5	6	7	7	7	7	0.707
0.164	NR	3	5	7	7	7	7	7	0.653
0.175	NR	3	6	7	8	8	8	8	0.605

Figure 6 Table AP-1A from Appendix B of Armor Plate Pipe Wrap Handbook

Table 1 Repaired Burst Test Samples

Sample Number	Sample Description	SMYS pressure	Predicted burst pressure for uncorroded pipe ⁽¹⁾	Predicted burst pressure for corroded pipe ⁽²⁾	Actual burst pressure ⁽³⁾
WC-3B	12.75" X 0.188" w.t. pipe, grade X52 50% corrosion (24" long by 8" wide) $t_{actual} = 0.191$ inches (base pipe material) $t_{min} = 0.078$ inches (in corrosion) Pipe yield strength = 49,000 psi Pipe tensile strength = 76,250 psi (7 wraps used, 7 reqd. by handbook tables)	1,533 psi	2,319 psi	974 psi	2,289 psi
WC-4F	12.75" X 0.188" w.t. pipe, grade X52 50% corrosion (24" long by 8" wide) $t_{actual} = 0.191$ inches (base pipe material) $t_{min} = 0.078$ inches (in corrosion) Pipe yield strength = 49,000 psi Pipe tensile strength = 76,250 psi (sample pressure cycled 3,290 times prior to burst with $\Delta P = 100$ to 1200 psi) (7 wraps used, 7 reqd. by handbook tables)	1,533 psi	2,319 psi	974 psi	2,313 psi
Pipe #2	6.625" X 0.280" w.t. pipe, grade X46 50% corrosion (4" long by 4" wide) $t_{actual} = 0.280$ inches (base pipe material) $t_{min} = 0.140$ inches (in corrosion) Pipe yield strength = 47,500 psi Pipe tensile strength = 70,600 psi (4 wraps used, 6 reqd. by handbook tables)	3,888 psi	6,231 psi	3,629 psi.	6,170 psi

Notes:

- (1) Predicted burst pressure based on actual wall thickness and ultimate tensile strength of pipe
- (2) Predicted burst pressures for corroded pipes based on ultimate strength of pipe and reduction factor to account for corroded wall thickness
- (3) Burst pressures for the repaired samples exceeded not only 100 percent SMYS, but were also greater than the predicted failure pressures for the base pipe material assuming no defects were present.

Table 2 Test Samples with Mechanical Damage Defects

Sample Number	Sample Characteristics	Failure Pressure
Pipe #3	Unrepaired mechanical damage (15% dent and 10% gouge)	3,750 psi
Pipe #4	Repaired mechanical damage (15% dent and 10% gouge) using 4 wraps of APPW 360 (dent filled with AP360 epoxy putty)	5,820 psi

Table 3 Tensile specimen dimensions and results

Specimen Number	Width (inches)	Thickness (inches)	Failure Strain (percent)	Failure Stress (psi)	Modulus of Elasticity (psi)	Notes (adhesive description)
A4-1	1.000	0.215	1.61	26,744	1.66 X 10 ⁶	standard AP 360 formulation
A4-2	1.003	0.209	1.47	25,044	1.70 X 10 ⁶	standard AP 360 formulation
A4-3	1.003	0.216	1.43	27,463	1.92 X 10 ⁶	standard AP 360 formulation
A4-4	1.001	0.214	1.53	26,515	1.73 X 10 ⁶	standard AP 360 formulation
B2-1L	1.005	0.111	1.38	30,478	2.21 X 10 ⁶	AP 360 long pot life (cure time)
B2-2L	1.001	0.113	1.37	26,433	1.93 X 10 ⁶	AP 360 long pot life (cure time)
B2-3L	1.005	0.112	1.40	27,007	1.93 X 10 ⁶	AP 360 long pot life (cure time)
B2-4L	1.001	0.110	1.36	26,337	1.94 X 10 ⁶	AP 360 long pot life (cure time)
B2-5H	1.002	0.111	1.02	24,276	2.38 X 10 ⁶	Standard AP 360 cured at 350°F
B2-6H	1.002	0.110	1.44	30,303	2.10 X 10 ⁶	Standard AP 360 cured at 350°F
B2-7H	1.006	0.115	1.32	25,845	1.96 X 10 ⁶	Standard AP 360 cured at 350°F
B2-8H	1.002	0.115	1.34	28,638	2.15 X 10 ⁶	Standard AP 360 cured at 350°F

Table 4 Lap shear specimen dimensions and results

Specimen Number	Adhesive Thickness (inches)	Adhesive Width (inches)	Adhesive Length (inches)	Failure Elongation (inches)	Failure Shear Stress (psi)	Adherend Type
B2-3L	0.013	0.996	1.332	0.010	1,492	steel on steel
B2-4L	0.010	0.995	1.286	0.011	1,516	steel on steel
B2-5H	0.014	0.998	1.342	0.019	1,755	composite on steel
B2-6H	0.013	0.995	1.340	0.013	1,440	composite on steel
B2-7H	0.014	1.000	1.360	0.014	1,463	composite on steel
B2-8H	0.015	0.975	1.368	0.013	1,322	composite on steel